

**SUBJECT:**

This document provides repair procedures of the Brush block assembly, and it:

**BRUSH ASSEMBLY REPLACEMENT**  
**BRUSH MODULE REPLACEMENT**  
**BRUSH REPLACEMENT**

CONTENTS:	Page:
I. GENERAL	1
II. NOMENCLATURE	1
III. LIST OF TOOLS	3
IV. BRUSH ASSEMBLY REPLACEMENT	4
V. BRUSH MODULE REPLACEMENT	6
VI. BRUSH REPLACEMENT	9

**I. GENERAL**

A. Brush assembly replacement, Brush module replacement or Brush replacement is not a periodic maintenance. It is applicable only in case of Brush block assembly malfunction.

B. In addition to this document use Propeller Installation and operational manual E-1500; EN-1320; EN-1366 (according to the propeller).

C. The user is responsible for maintaining the current status of this document according to the changes made. A valid revision of this document is freely available at [www.aviapropeller.com](http://www.aviapropeller.com).

**II. NOMENCLATURE**

**The brush block assembly** consists of Brush assembly, bracket and fasteners. The brush block assembly may have Speed sensor (optionally).

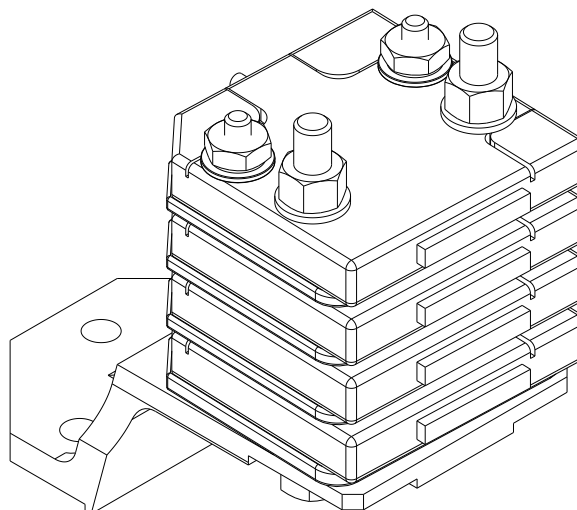



Fig.1 The brush block assembly (e.g. 4-races version)

*The technical content of this document is approved under authority of DOA No. EASA.21J.072.*

Office of Airworthiness Zbyněk Tvrdík Date: May 22, 2017 	Prepared by: Pavel Demkovič Date: May 22, 2017 	Page : 1 Pages : 13
---	---	------------------------

**Brush assembly** consists of several Brush modules, washers and fasteners.

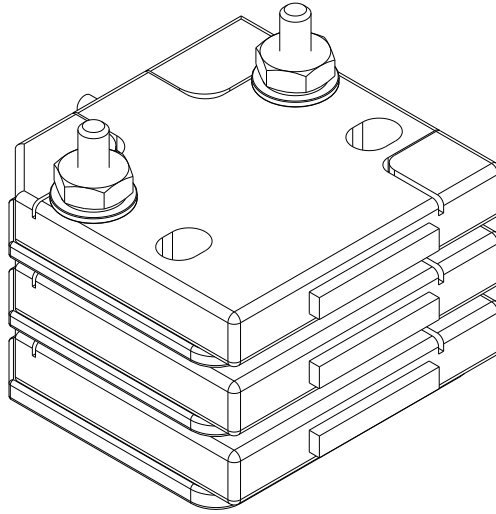

Fig.2 Brush assembly (e.g. 3-races version)

**Brush module** consists of module body, brush, spring, screw, lock washer and spacer (if existing).

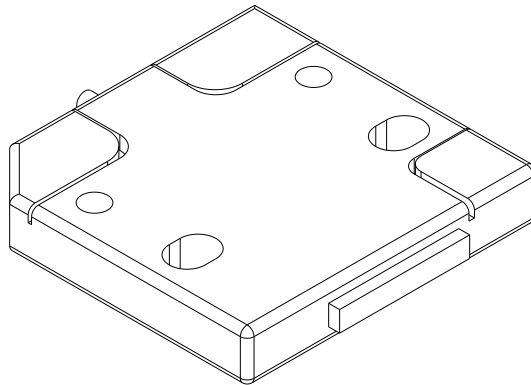

Fig.3 Brush module

**Brush** (replacement kit) consists of brush with guide rod and lead wire, insulating tube, ring terminal and identifying stickers.

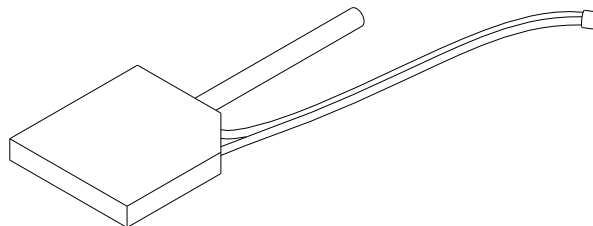



Fig.4 Replacement brush without ring terminal, insulating tube and identifying stickers

*The technical content of this document is approved under authority of DOA No. EASA.21J.072.*



Office of Airworthiness Zbyněk Tvrđík Date: May 22, 2017 	Prepared by: Pavel Demkovič Date: May 22, 2017 		Page : 2 Pages : 13
---	---	--	------------------------

AVIA PROPELLER Ltd Beranových 65/666 199 00 Praha 9 Czech Republic	<b>SERVICE ADVISORY</b> <b>SA-11</b>	DOA No. EASA.21J.072
---	---	-------------------------

### III. LIST OF TOOLS

- Nippers for cutting off safety wire on the engine gear box and cutting off wire of the brush (for brush replacement)
- Wire pliers for screw locking with safety wire
- 1x Spanner No.8mm and 1x ratchet with socket No.8 (or other suitable wrench – e.g. tubular socket wrench)
- 1x Cross screwdriver - type PH2
- 1x Torque wrench (with range from 0 Nm) with socket No.8 for tightening the brush assembly to the bracket
- Crimping tool for crimping the ring terminal
- Rubber band for securing pressed brush, or e.g. paper adhesive tape

*The technical content of this document is approved under authority of DOA No. EASA.21J.072.*

Office of Airworthiness Zbyněk Tvrdík  Date: May 22, 2017	Prepared by: Pavel Demkovič  Date: May 22, 2017		Page : 3 Pages : 13
--	--	--	------------------------

## IV. BRUSH ASSEMBLY REPLACEMENT

### 1. GENERAL

A. This section provides disassembly procedure for the Brush assembly replacement.

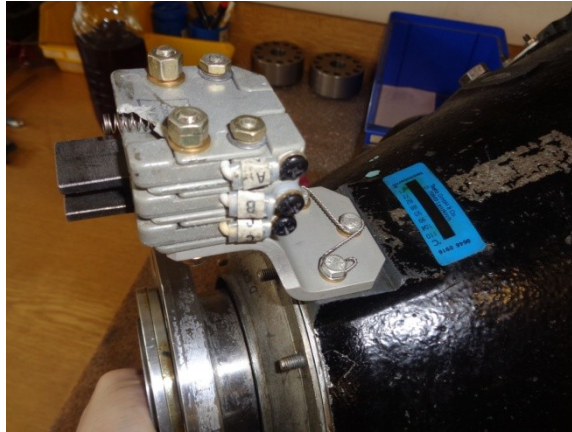

Fig.5 Damaged brush block assembly mounted on the engine gear box (e.g. 3-races version)

### 2. PROCEDURE FOR DISASSEMBLY AND ASSEMBLY

A. First disassembly damaged Brush block assembly from the engine gear box for easy replacement.

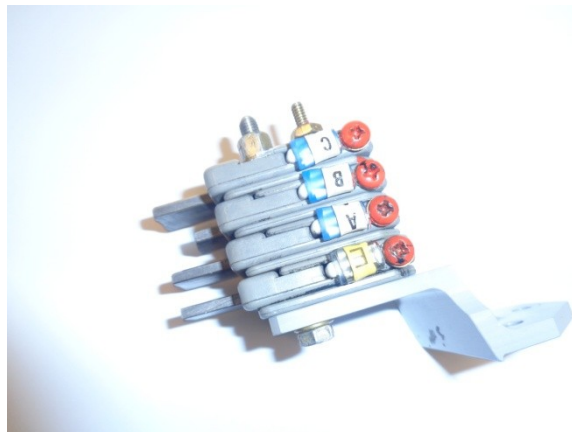



Fig.6 Damaged brush block assembly removed from engine gear box (e.g. 4-races version)

B. Remove the two M5 screws from self locking nuts (see red arrows in the Fig.7), remove brush assembly from bracket (Note: Do not loose low profile nuts with thin screws (No.6-32 UNC = Approx  $\varnothing 3,5\text{mm}$ ) – It would release Brush blocks and move them relative to each other)

*The technical content of this document is approved under authority of DOA No. EASA.21J.072.*

Office of Airworthiness Zbyněk Tvrđík Date: May 22, 2017 	Prepared by: Pavel Demkovič Date: May 22, 2017 		Page : 4 Pages : 13
---	---	--	------------------------

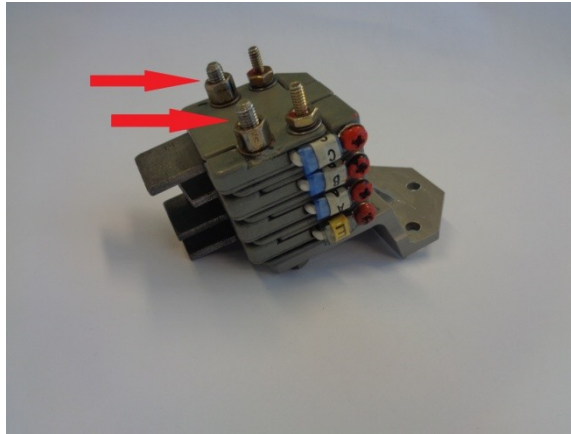

Fig.7 Loose screws and nuts marked with red arrows for disassembly Brush block assembly

- C. Install a new or repaired brush assembly on the original bracket using the original fasteners if it has not been damaged. Do not fully tighten the screw connection and follow Installation and operation manual for your propeller – section Brush block installation.

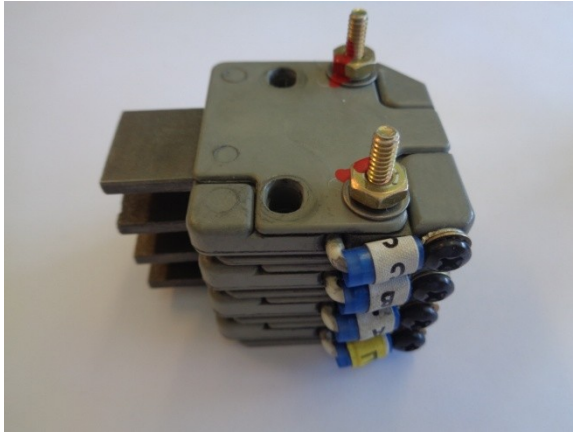

Fig.8 New Brush assembly (for replacement)

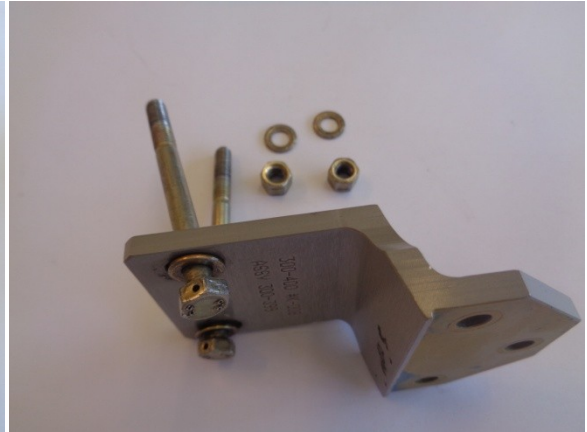

Fig.9 Used original console with fasteners

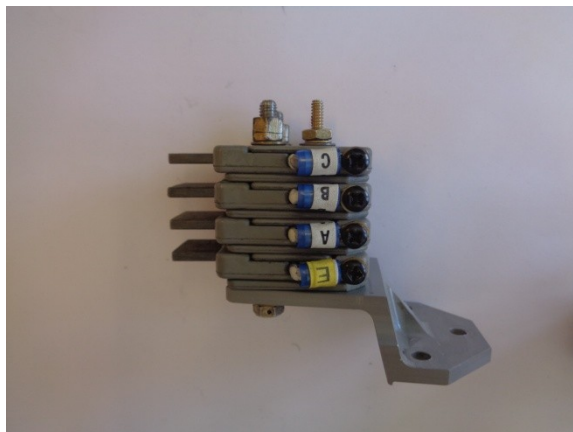

Fig.10 Brush block assembly with new brush assembly

*The technical content of this document is approved under authority of DOA No. EASA.21J.072.*

Office of Airworthiness Zbyněk Tvrdík Date: May 22, 2017	Prepared by: Pavel Demkovič Date: May 22, 2017		Page : 5 Pages : 13
--	--	--	------------------------

## V. BRUSH MODULE REPLACEMENT

### 1. GENERAL

- A. This section provides disassembly procedure for the Brush module replacement.



Fig.11 Damaged 3-races Brush assembly



Fig.12 Damaged 4-races Brush assembly

### 2. PROCEDURE FOR DISASSEMBLY AND ASSEMBLY

- A. First disassembly damaged Brush assembly from Brush block assembly – see part IV. from this document.
- B. Loose two screw connections (see red arrows on fig.13) and remove all damaged brush modules.

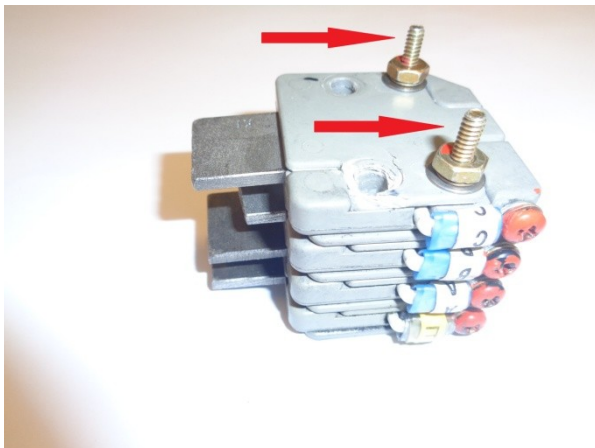

Fig.13 Loose two screw connections for disassembly the Brush assembly

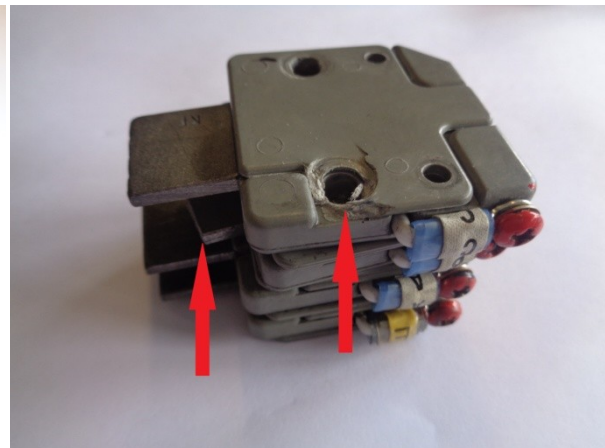



Fig.14 Damaged Brush modules for replacement

*The technical content of this document is approved under authority of DOA No. EASA.21J.072.*

Office of Airworthiness Zbyněk Tvrdík Date: May 22, 2017 	Prepared by: Pavel Demkovič Date: May 22, 2017 		Page : 6 Pages : 13
---	---	--	------------------------

AVIA PROPELLER Ltd Beranových 65/666 199 00 Praha 9 Czech Republic	<b>SERVICE ADVISORY</b> <b>SA-11</b>	DOA No.  EASA.21J.072
---	---	-----------------------------

C. Damaged Brush modules can be replaced for same version – i.e. A for A („A“ – P/N 3E2011-15), B for B („B“ – P/N 3E2011-16) and C for C („C“ – P/N 3E2011-17), or universal P/N 3E2011-10 for any (then mark ring terminal with correct letter at identifying stickers).



Fig.15 New replacement Brush blocks „A“ „B“ „C“



Fig.16 New universal replacement Brush block P/N 3E2011-10

D. Remount Brush assembly as shown on Fig.17.

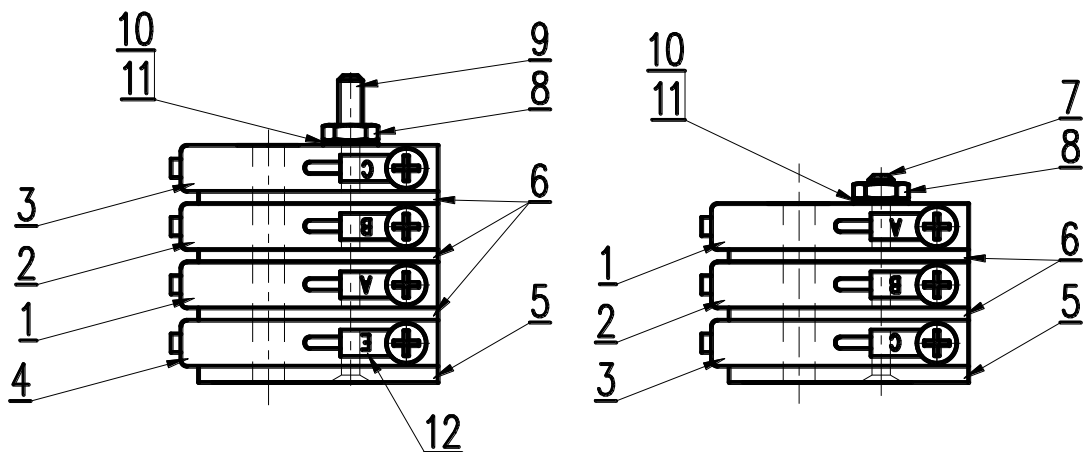

Fig.17 Brush assembly 4-races and/or 3-races

Position	Name	Marking (P/N)
1	Brush module	3E2011-15
2	Brush module	3E2011-16
3	Brush module	3E2011-17
4	Brush module	3E2011-15 or 3E2011-16 or 3E2011-17 or 3E2011-10
5	Washer	4E2218-4
6	Washer	4E2218-3
7	Screw	MS24693-S36
8	Nut	MS35649-262
9	Screw	MS24693-S40
10	Washer	NAS1149CN632R (AN960C6)
11	Serrated washer	MS35333-37
12	Identifying shrink tube, or sticker	-

The technical content of this document is approved under authority of DOA No. EASA.21J.072.

Office of Airworthiness Zbyněk Tvrđík Date: May 22, 2017	Prepared by: Pavel Demkovič Date: May 22, 2017		Page : 7  Pages : 13
--	--	--	----------------------------

Place the Brush assembly on the back of the Brush assembly and remount the Brush assembly on a flat and solid table with using cross screwdriver and spanner. See fig.18.





Fig.18 Remount Brush assembly on a flat and solid table

Note: When tightening the Brush assembly, make sure that the Brush assembly is firmly tightened but at the same time to prevent the screw joints from dropping and the destruction of the brush block body closest to the washers and nuts (see fig.14). Recommended tightening torque is 1Nm.

- E. Remount Brush assembly according to IV. section in this document.

*The technical content of this document is approved under authority of DOA No. EASA.21J.072.*

Office of Airworthiness Zbyněk Tvrđík Date: May 22, 2017 	Prepared by: Pavel Demkovič Date: May 22, 2017 		Page : 8 Pages : 13
---	---	--	------------------------



AVIA PROPELLER Ltd Beranových 65/666 199 00 Praha 9 Czech Republic	<b>SERVICE ADVISORY</b> <b>SA-11</b>	DOA No. EASA.21J.072
---	---	-------------------------

## VI. BRUSH REPLACEMENT

### 1. GENERAL

- A. This section provides procedure for the Brush replacement.



Fig.19 Brush module with damaged Brush

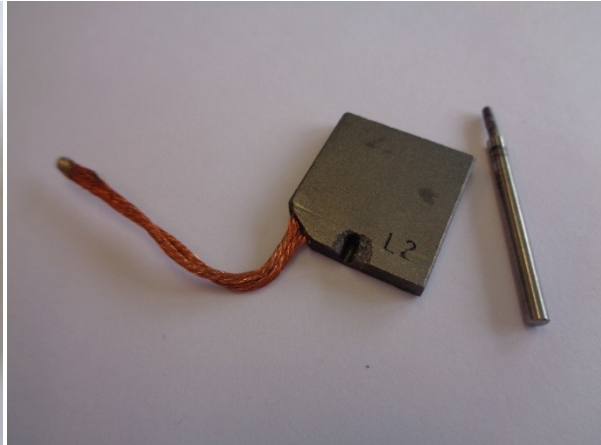

Fig.20 Damaged Brush

### 2. PROCEDURE FOR DISASSEMBLY AND ASSEMBLY

- A. First disassembly damaged Brush assembly from Brush block assembly – see part IV. from this document. Next disassembly Brush module with damaged Brush from Brush assembly – see part V. from this document.



Fig.21 Brush module with damaged Brush

- B. Unscrew the screw from the ring terminal. For easier cutting, compress the Brush into module body. Cut the cable behind the ring terminal.

*The technical content of this document is approved under authority of DOA No. EASA.21J.072.*

Office of Airworthiness Zbyněk Tvrdík Date: May 22, 2017	Prepared by: Pavel Demkovič Date: May 22, 2017		Page : 9 Pages : 13
--	--	--	------------------------

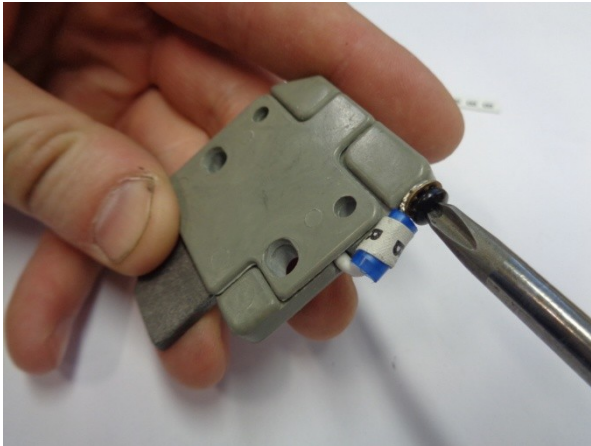

Fig.22 Screw removing from the ring terminal

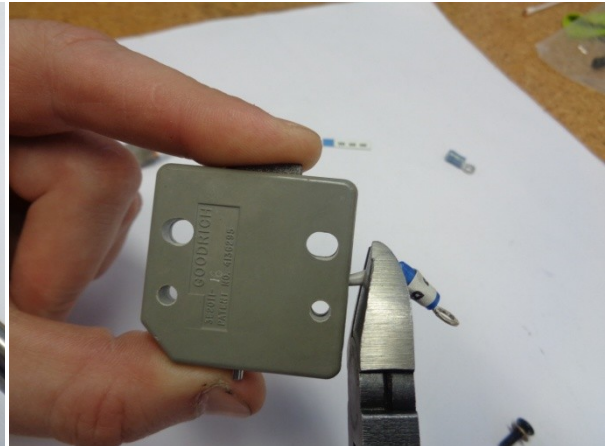

Fig.23 Cut the cable behind the ring terminal

- C. Remove the damaged Brush with rod including all broken parts. Only the spring must remain inside the module body (see fig.25).

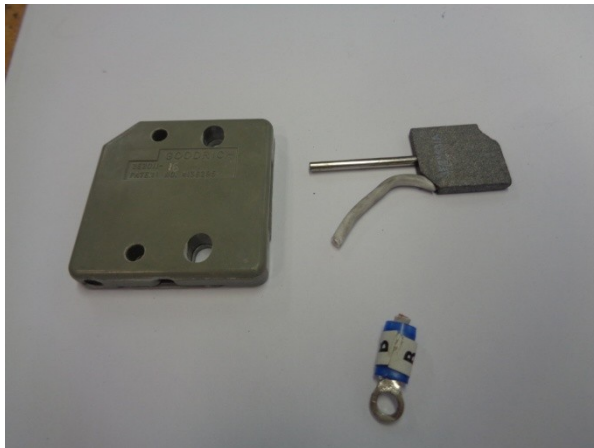

Fig.24 Module body with removed damaged Brush and cut-off ring terminal



Fig.25 Empty module body with spring inside

- D. Prepare a replacement Brush 3E2563-1 (supplier Goodrich).



Fig.26 Replacement Brush 3E2563-1

The technical content of this document is approved under authority of DOA No. EASA.21J.072.

Office of Airworthiness Zbyněk Tvrdík Date: May 22, 2017	Prepared by: Pavel Demkovič Date: May 22, 2017		Page : 10 Pages : 13
--	--	--	-------------------------

- E. Slide insulating tube over brush lead so that the end of tubing almost contacts the brush. If the brush lead is poorly sliding through the insulating tube, a thread may be used. Thread a cord through brush leads and stretch it through insulating tube. Now slide insulating tube over brush.

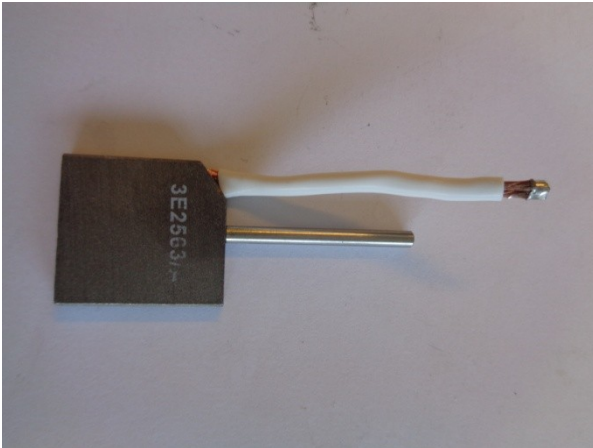

Fig.27 Brush with threaded insulating tube

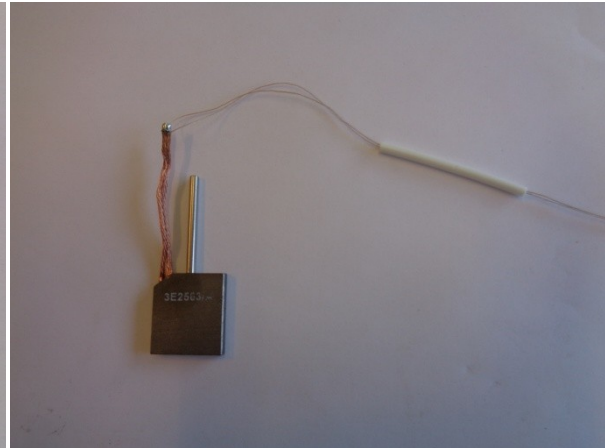

Fig.28 A brush with a thread for easier passage of lead through the insulating tube

- F. For easier installation form the lead of the Brush per fig.29. Then insert Brush into module body per fig.30. Ensure that the guide rod is in the spring and at the same time that the lead protrudes through the lead exit hole – see blue arrow in the fig.30.

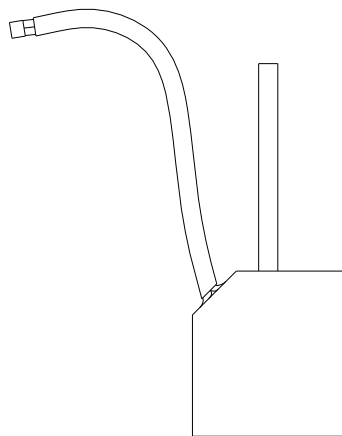

Fig.29 Recommended forming of the lead before installation

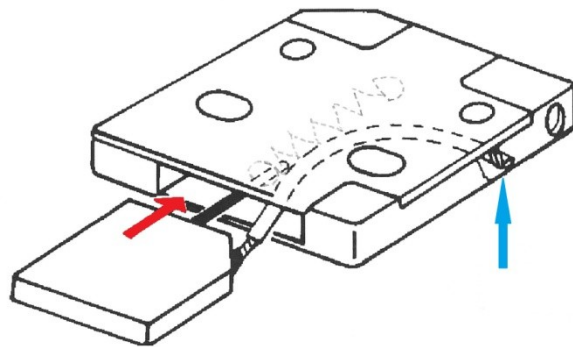

Fig.30 Insert Brush into module body

*The technical content of this document is approved under authority of DOA No. EASA.21J.072.*

Office of Airworthiness Zbyněk Tvrdík Date: May 22, 2017	Prepared by: Pavel Demkovič Date: May 22, 2017		Page : 11 Pages : 13
--	--	--	-------------------------

- G. Fully compress the brush and secure it with a rubber band, or paper adhesive tape. Pull the lead out of the exit hole until the maximum available lead length is external to the brush module and slide the tubing on the lead to within 3/16 inch (4,76mm) (if necessary, shorten the insulation tube) of the end of the bare wire (see fig.31).

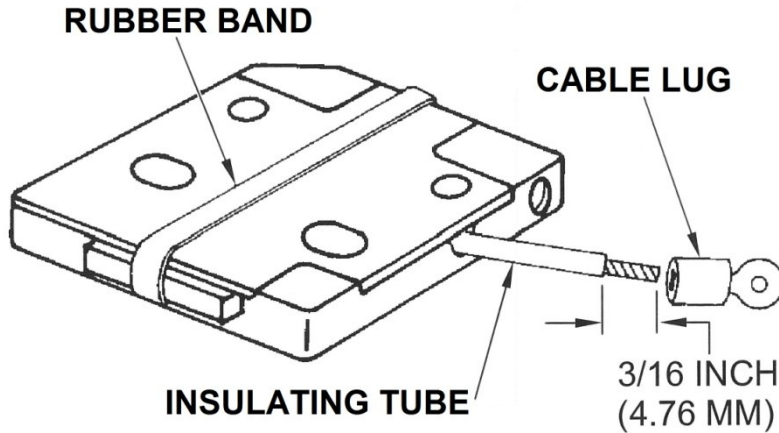

Fig.31 Preparation of the brush wire to crimp the ring terminal

- H. Install the ring terminal so that the end of the tubing is positioned inside the jacket of the ring terminal and no bare wire is exposed (see fig.32). Crimp the ring terminal in place with crimping tool. After crimping degrease ring terminal with technical gasoline and mark it with correct identifying sticker.

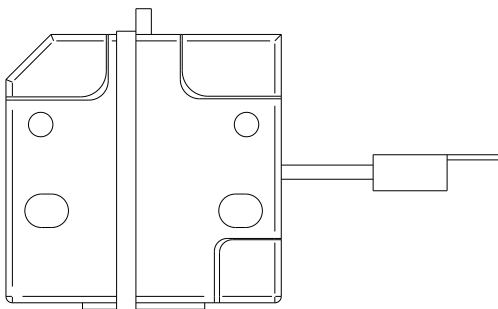

Fig.32 Position of the ring terminal



Fig.33 Ring terminal degreasing



Fig.34 Ring terminal degreasing

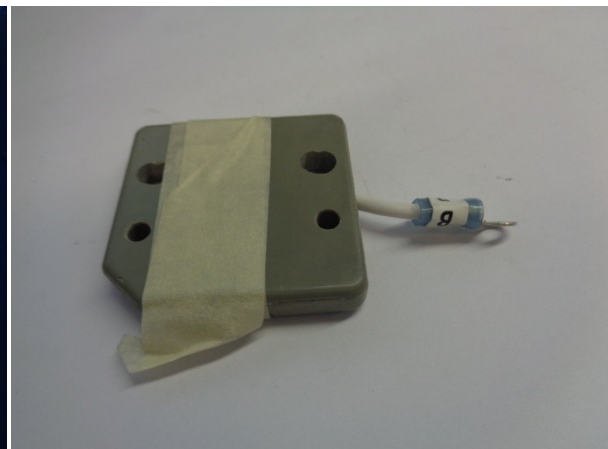

Fig.35 Mark with identifying sticker

The technical content of this document is approved under authority of DOA No. EASA.21J.072.

Office of Airworthiness Zbyněk Tvrđík Date: May 22, 2017	Prepared by: Pavel Demkovič Date: May 22, 2017		Page : 12 Pages : 13
--	--	--	-------------------------

- I. Remove the rubber band (or paper adhesive tape) and carefully pull the brush until all slack on the lead is encased in the module (see fig.36). Attach ring terminal with screw and washers into module base (see fig.37).



Fig.36 Remove the rubber band and release the brush; insert back all fasteners

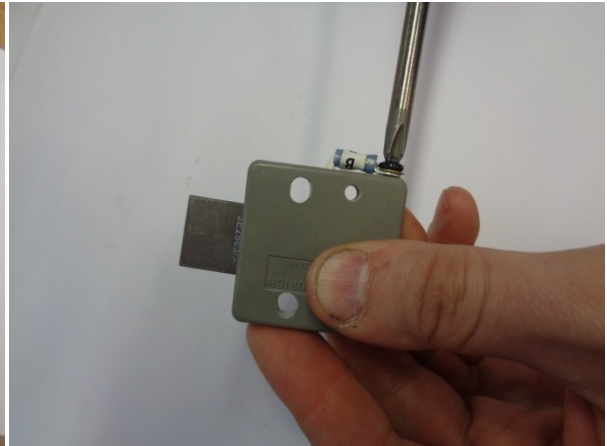



Fig.37 Attaching ring terminal to the module base

- J. Test the motion of the brush so that compress it several time. Brush moving must be smooth.
- K. Remount Brush module according to V.section in this document and Brush assembly according to IV. section in this document.

*The technical content of this document is approved under authority of DOA No. EASA.21J.072.*

Office of Airworthiness Zbyněk Tvrdík Date: May 22, 2017 	Prepared by: Pavel Demkovič Date: May 22, 2017 		Page : 13 Pages : 13
---	---	--	-------------------------